

# UNICARRIERS<sup>®</sup>

## □ FORKLIFT □



# Platinum GO4 LPG

Engine Powered Forklifts

LPG & Dual Fuel

8,000 - 11,000 lbs. Capacities | Pneumatic Tire



# S P E C I F I C A T I O N S

## MAIN TRUCK SPECIFICATIONS

CHARACTERISTICS	1	Manufacturer's Name			UniCarriers		UniCarriers	
	2	Model	Model designation	1 Spd / 2 Spd	PF80Y(H)LP	PF80Y(H)DF	PF90Y(H)LP	PF90Y(H)DF
	3	Long model code		1 Spd / 2 Spd	MJ1F4A(F)35LV	MJ1F4A(F)35DV	MJ1F4A(F)40LV	MJ1F4A(F)40DV
	4	Power Type			LP	Dual Fuel	LP	Dual Fuel
	5	Rated Load Capacity		lb (kg)	8000 (3500)		9000 (4000)	
	6	Load Center	Distance	in (mm)	24 (600)		24 (600)	
	7	Operator Orientation			Sit		Sit	
DIMENSIONS	8	Tire Type	Front & rear		Pneumatic		Pneumatic	
	9	Wheels	Number - front/rear(x=driven)		2x / 2		2x / 2	
	10	Mast	Maximum fork height	in (mm)	130 (3300)		130 (3300)	
	11		Mast lowered (OHL)	in (mm)	90.4 (2300)		90.4 (2300)	
	12		Mast extended with LBR	in (mm)	181.1 (4600)		181.1 (4600)	
	13		Standard freelif	in (mm)	5.1 (130)		5.1 (130)	
	14	Forks	Length x thickness x width	in (mm)	48 x 2 x 6 (1220 x 50 x 150)		48 x 2 x 6 (1220 x 50 x 150)	
	15	Tilt Angle	Standard mast - fwd/back	degree	6 / 12		6 / 12	
	16	Overall Dimensions	Length (to face of forks)	in (mm)	121.8 (3095)		123.1 (3130)	
	17		Height - top of OHG	in (mm)	92.5 (2350)		92.5 (2350)	
	18		Height - top of standard LBR	in (mm)	48.0 (1220)		48.0 (1220)	
	19		Width - standard carriage	in (mm)	47.2 (1200)		47.2 (1200)	
	20	Overall Width	Width - single tire / single wide tire	in (mm)	58.7 (1490) / 58.7 (1490)		— / 58.7 (1490)	
	21		Width - dual tire / dual wide tire	in (mm)	69.9 (1775) / 77.6 (1975)		69.9 (1775) / 77.6 (1975)	
	22	Overhang	Front / rear	in (mm)	22.0 (560) / 21.1 (535)		22.0 (560) / 22.4 (570)	
	23	Turning Radius	Minimum outside	in (mm)	107.1 (2720)		108.3 (2755)	
24	Min Right Angle Stack	Add load length & clearance	in (mm)	129.1 (3280)		130.3 (3315)		
PERFORMANCE	25	Travel Speed Forward	Maximum* - 1st Speed / 2nd speed	mph (km/h)	11.2 (18) / 13.7 (22)		11.2 (18) / 13.7 (22)	
	26	Lifting Speed	Maximum - loaded / unloaded	fpm (mm/sec)	94.5 (480) / 94.5 (480)		94.5 (480) / 94.5 (480)	
	27	Lowering Speed	Maximum - loaded / unloaded	fpm (mm/sec)	98.4 (500) / 98.4 (500)		98.4 (500) / 98.4 (500)	
	28	Drawbar Pull Maximum	Full load - at 1 mph	lb (N)	6865 (30500)		7065 (31400)	
	29		No load - at 1 mph	lb (N)	5875 (26100)		6070 (27000)	
	30	Gradeability Maximum	Full load / no load - at 1 mph	%	32 / 27		28 / 26	
WEIGHT	31	Truck Weight	No load - standard truck	lb (kg)	12890 (5840)		13390 (6065)	
	32	Weight Distribution	Front axle - empty	lb (kg)	5685 (2575)		5630 (2550)	
	33		Rear axle - empty	lb (kg)	7210 (3265)		7760 (3515)	
	34		Front axle - with rated load	lb (kg)	17890 (8105)		19580 (8870)	
	35		Rear axle - with rated load	lb (kg)	2725 (1235)		2635 (1195)	
CHASSIS & WHEELS	36	Wheelbase		in (mm)	78.5 (2000)		78.5 (2000)	
	37	Tire Size	Front Tread - single / single wide		8.25 x 15-14PR / 300 x 15-18PR		— / 300 x 15-18PR	
	38		Front Tread - dual / dual wide		7.50 x 16-12PR / 8.25 x 15-12PR		7.50 x 16-12PR / 8.25 x 15-12PR	
	39		Rear Tread		7.00 x 12-12PR		7.00 x 12-12PR	
	40	Tread - Center of Tire	Front Tread - single / single wide	in (mm)	49.2 (1250) / 46.5 (1180)		— / 46.5 (1180)	
	41		Front Tread - dual / dual wide	in (mm)	51.5 (1310) / 56.9 (1445)		51.5 (1310) / 56.9 (1445)	
	42		Rear Tread	in (mm)	46.5 (1180)		46.5 (1180)	
	43	Seat Height		in (mm)	46.0 (1170)		46.0 (1170)	
	44	Headroom	SIP to bottom of OHG	in (mm)	40 (1015)		40 (1015)	
	45	Counterweight Height		in (mm)	50.2 (1275)		50.2 (1275)	
	46	Step Height		in (mm)	18.7 (475)		18.7 (475)	
	47	Floor Height		in (mm)	31.3 (795)		31.3 (795)	
	48	Ground Clearance	Under mast / power unit / frame	in (mm)	5.7 (145) / 6.7 (170) / 8.9 (225)		5.7 (145) / 6.7 (170) / 8.9 (225)	
	49	Service Brake	Type		Foot, Hydraulic Boost		Foot, Hydraulic Boost	
50	Parking Brake	Type		Hand, Mechanical		Hand, Mechanical		
DRIVE LINE	51	Steering	Type		Hydrostatic, Power		Hydrostatic, Power	
	52	Engine	Model		GCT TB45		GCT TB45	
	53	Rated Output	SAE gross - LP, Diesel	hp(kW)@rpm	85.7 (63.9) @ 2450		85.7 (63.9) @ 2450	
	54	Rated Torque	SAE gross - LP, Diesel	ft-lb(Nm)@rpm	212 (288) @ 1600		212 (288) @ 1600	
	55	Displacement		cu in (cm <sup>3</sup> )	273 (4478)		273 (4478)	
	56	Transmission Speeds	Powershift type		1 forward / 1 reverse		1 forward / 1 reverse	
	57		Automatic type		2 forward / 1 reverse		2 forward / 1 reverse	

\* Travel speeds are the same for loaded and unloaded conditions.

## MAIN TRUCK SPECIFICATIONS

CHARACTERISTICS	1	Manufacturer's Name		UniCarriers		UniCarriers		
	2	Model	Model designation	1 Spd / 2 Spd	PF100Y(H)LP	PF100Y(H)DF	PF110Y(H)LP	PF110Y(H)DF
	3		Long model code	1 Spd / 2 Spd	MJ1F4A(F)45LV	MJ1F4A(F)45DV	MJG1F4A(F)50LV	MJG1F4A(F)50DV
	4	Power Type			LP	Dual Fuel	LP	Dual Fuel
	5	Rated Load Capacity		lb (kg)	10000 (4500)		11000 (5000)	
	6	Load Center	Distance	in (mm)	24 (600)		24 (600)	
	7	Operator Orientation			Sit		Sit	
DIMENSIONS	8	Tire Type	Front & rear		Pneumatic		Pneumatic	
	9	Wheels	Number - front/rear(x=driven)		2x / 2		2x / 2	
	10	Mast	Maximum fork height	in (mm)	130 (3300)		130 (3300)	
	11		Mast lowered (OHL)	in (mm)	90.4 (2300)		90.4 (2300)	
	12		Mast extended with LBR	in (mm)	181.1 (4600)		181.1 (4600)	
	13		Standard freelif	in (mm)	6.9 (175)		6.9 (175)	
	14	Forks	Length x thickness x width	in (mm)	48 x 2 x 6 (1220 x 50 x 150)		48 x 2 x 6 (1220 x 50 x 150)	
	15	Tilt Angle	Standard mast - fwd/back	degree	6 / 12		6 / 12	
	16	Overall Dimensions	Length (to face of forks)	in (mm)	126.4 (3210)		131.5 (3340)	
	17		Height - top of OHG	in (mm)	92.5 (2350)		92.5 (2350)	
	18		Height - top of standard LBR	in (mm)	48.0 (1220)		48.0 (1220)	
	19		Width - standard carriage	in (mm)	47.2 (1200)		47.2 (1200)	
	20	Overall Width	Width - single wide tire	in (mm)	58.7 (1490)		58.7 (1490)	
	21		Width - dual tire / dual wide tire	in (mm)	69.9 (1775) / 77.6 (1975)		69.9 (1775) / 77.6 (1975)	
	22	Overhang	Front / rear	in (mm)	23.1 (587) / 24.5 (622)		23.5 (597) / 23.3 (593)	
	23	Turning Radius	Minimum outside	in (mm)	110.2 (2800)		115.6 (2940)	
	24	Min Right Angle Stack	Add load length & clearance	in (mm)	133.3 (3387)		139.1 (3537)	
PERFORMANCE	25	Travel Speed Forward	Maximum* - 1st Speed / 2nd speed	mph (km/h)	11.2 (18) / 13.7 (22)		11.2 (18) / 13.7 (22)	
	26	Lifting Speed	Maximum - loaded / unloaded	fpm (mm/sec)	82.7 (420) / 82.7 (420)		82.7 (420) / 82.7 (420)	
	27	Lowering Speed	Maximum - loaded / unloaded	fpm (mm/sec)	88.6 (450) / 88.6 (450)		88.6 (450) / 88.6 (450)	
	28	Drawbar Pull Maximum	Full load - at 1 mph	lb (N)	7260 (32300)		7470 (33200)	
	29		No load - at 1 mph	lb (N)	6280 (27900)		6480 (28800)	
	30	Gradeability Maximum	Full load / no load - at 1 mph	%	25 / 24		23 / 22	
WEIGHT	31	Truck Weight	No load - standard truck	lb (kg)	15185 (6880)		16300 (7385)	
	32	Weight Distribution	Front axle - empty	lb (kg)	6115 (2770)		6745 (3055)	
	33		Rear axle - empty	lb (kg)	9070 (4110)		9560 (4330)	
	34		Front axle - with rated load	lb (kg)	21940 (9940)		23920 (10835)	
	35		Rear axle - with rated load	lb (kg)	3180 (1440)		3420 (1550)	
CHASSIS & WHEELS	36	Wheelbase		in (mm)	78.5 (2000)		84.5 (2150)	
	37	Tire Size	Front Tread - single wide		300 x 15-18PR		300 x 15-18PR	
	38		Front Tread - dual / dual wide		7.50 x 16-12PR / 8.25 x 15-12PR		7.50 x 16-12PR / 8.25 x 15-12PR	
	39		Rear Tread		7.00 x 12-16PR		7.00 x 12-16PR	
	40	Tread - Center of Tire	Front Tread - single wide	in (mm)	46.5 (1180)		46.5 (1180)	
	41		Front Tread - dual / dual wide	in (mm)	51.5 (1310) / 56.9 (1445)		51.5 (1310) / 56.9 (1445)	
	42		Rear Tread	in (mm)	46.5 (1180)		46.5 (1180)	
	43	Seat Height		in (mm)	46.0 (1170)		46.0 (1170)	
	44	Headroom	SIP to bottom of OHG	in (mm)	40 (1015)		40 (1015)	
	45	Counterweight Height		in (mm)	50.2 (1275)		50.2 (1275)	
	46	Step Height		in (mm)	18.7 (475)		18.7 (475)	
	47	Floor Height		in (mm)	31.3 (795)		31.3 (795)	
	48	Ground Clearance	Under mast / power unit / frame	in (mm)	5.7 (145) / 6.7 (170) / 8.9 (225)		5.7 (145) / 6.7 (170) / 8.9 (225)	
	49	Service Brake	Type		Foot, Hydraulic Boost		Foot, Hydraulic Boost	
	50	Parking Brake	Type		Hand, Mechanical		Hand, Mechanical	
DRIVE LINE	51	Steering	Type		Hydrostatic, Power		Hydrostatic, Power	
	52	Engine	Model		GCT TB45		GCT TB45	
	53	Rated Output	SAE gross - LP, Diesel	hp(kW)@rpm	85.7 (63.9) @ 2450		85.7 (63.9) @ 2450	
	54	Rated Torque	SAE gross - LP, Diesel	ft-lb(Nm)@rpm	212 (288) @ 1600		212 (288) @ 1600	
	55	Displacement		cu in (cm <sup>3</sup> )	273 (4478)		273 (4478)	
	56	Transmission Speeds	Powershift type		1 forward / 1 reverse		1 forward / 1 reverse	
		Automatic type		2 forward / 1 reverse		2 forward / 1 reverse		

\* Travel speeds are the same for loaded and unloaded conditions.

## DIMENSIONS

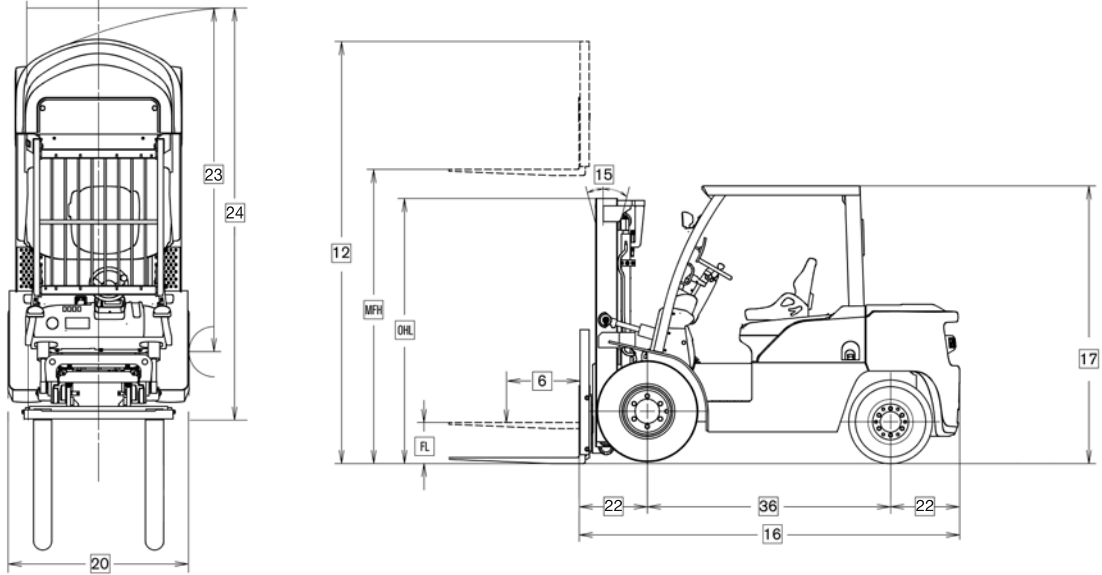

## MAST SPECIFICATIONS & RATED CAPACITIES

Mast Type	Mast Name	Maximum Fork Height	Overall Height				Free Lift		Tilt Angle	Rated Capacity at 24 in (600mm) Load Center			
			Lowered	Fully Extended		With LBR	Without LBR	Fwd/Bkwd		PF80Y		PF90Y	
				in (mm)	in (mm)				With LBR	Without LBR	Single Drive	Dual Drive	Single Drive
TWO STAGE (Wide view)	2W300	118 (3000)	84.4 (2150)	169.3 (4300)	151.0 (3835)	5.1 (130)	5.1 (130)	6/12	8000 (3500)	8000 (3500)	9000 (4000)	9000 (4000)	
	2W30	130 (3300)	90.4 (2300)	181.1 (4600)	162.8 (4135)	5.1 (130)	5.1 (130)	6/12	8000 (3500)	8000 (3500)	9000 (4000)	9000 (4000)	
	2W350	138 (3500)	95.7 (2435)	189.0 (4800)	170.7 (4335)	5.1 (130)	5.1 (130)	6/12	8000 (3500)	8000 (3500)	9000 (4000)	9000 (4000)	
	2W370	146 (3700)	100.2 (2550)	196.9 (5005)	178.5 (4535)	5.1 (130)	5.1 (130)	6/12	8000 (3500)	8000 (3500)	9000 (4000)	9000 (4000)	
	2W400	157 (4000)	108.1 (2750)	208.7 (5300)	190.4 (4835)	5.1 (130)	5.1 (130)	6/12	8000 (3500)	8000 (3500)	9000 (4000)	9000 (4000)	
	2W450	177 (4500)	117.9 (3000)	228.3 (5800)	210.0 (5335)	5.1 (130)	5.1 (130)	6/6	8000 (3500)	8000 (3500)	9000 (4000)	9000 (4000)	
THREE STAGE (Full free)	2W500	197 (5000)	127.8 (3250)	248.0 (6300)	229.7 (5835)	5.1 (130)	5.1 (130)	6/6	8000 (3500)	8000 (3500)	9000 (4000)	9000 (4000)	
	3F385	152 (3850)	78.5 (2000)	202.8 (5055)	186.0 (4725)	29.5 (750)	46.3 (1175)	6/6	8000 (3500)	8000 (3500)	9000 (4000)	9000 (4000)	
	3F430	169 (4300)	84.4 (2150)	220.5 (5600)	203.7 (4175)	35.4 (900)	52.2 (1325)	6/6	8000 (3500)	8000 (3500)	9000 (4000)	9000 (4000)	
	3F475	187 (4750)	90.4 (2300)	238.2 (6050)	221.5 (5625)	41.3 (1050)	58.1 (1475)	6/6	8000 (3500)	8000 (3500)	9000 (4000)	9000 (4000)	
	3F515	203 (5150)	95.7 (2435)	253.9 (6450)	237.2 (6025)	46.7 (1185)	63.4 (1610)	6/6	7800 (3400)	8000 (3500)	8700 (3850)	8700 (3850)	
	3F550	217 (5500)	100.2 (2550)	267.7 (6800)	251.0 (6375)	51.2 (1300)	67.9 (1725)	6/6	5300 (2300)	7600 (3300)	6900 (3050)	8500 (3750)	
3F600	236 (6000)	108.1 (2750)	287.4 (7300)	270.7 (6875)	59.1 (1500)	75.8 (1925)	6/6	4000 (1750)	7200 (3150)	5200 (2300)	8300 (3650)		

## MAST SPECIFICATIONS & RATED CAPACITIES

Mast Type	Mast Name	Maximum Fork Height	Overall Height				Free Lift		Tilt Angle	Rated Capacity at 24 in (600mm) Load Center			
			Lowered	Fully Extended		With LBR	Without LBR	Fwd/Bkwd		PF100Y		PF110Y	
				in (mm)	in (mm)				With LBR	Without LBR*	Single Drive	Dual Drive	Single Drive
TWO STAGE (Wide view)	2W300	118 (3000)	84.4 (2150)	169.3 (4300)	153.0 (3890)	6.9 (175)	6.9 (175)	6/12	10000 (4500)	10000 (4500)	11000 (5000)	11000 (5000)	
	2W330	130 (3300)	90.4 (2300)	181.1 (4600)	164.8 (4185)	6.9 (175)	6.9 (175)	6/12	10000 (4500)	10000 (4500)	11000 (5000)	11000 (5000)	
	2W350	138 (3500)	95.7 (2435)	189.0 (4800)	172.6 (4385)	6.9 (175)	6.9 (175)	6/12	10000 (4500)	10000 (4500)	11000 (5000)	11000 (5000)	
	2W370	146 (3700)	100.2 (2550)	196.9 (5005)	180.5 (4585)	6.9 (175)	6.9 (175)	6/12	10000 (4500)	10000 (4500)	11000 (5000)	11000 (5000)	
	2W400	157 (4000)	108.1 (2750)	208.7 (5300)	192.3 (4885)	6.9 (175)	6.9 (175)	6/12	10000 (4500)	10000 (4500)	11000 (5000)	11000 (5000)	
	2W450	177 (4500)	117.9 (3000)	228.3 (5800)	212.0 (5385)	6.9 (175)	6.9 (175)	6/6	10000 (4500)	10000 (4500)	11000 (5000)	11000 (5000)	
THREE STAGE (Full free)	2W500	197 (5000)	127.8 (3250)	248.0 (6300)	231.7 (5885)	6.9 (175)	6.9 (175)	6/6	10000 (4500)	10000 (4500)	11000 (5000)	11000 (5000)	
	3F385	152 (3850)	84.4 (2150)	202.8 (5150)	186.4 (4735)	35.6 (905)	52.0 (1320)	6/6	10000 (4500)	10000 (4500)	11000 (5000)	11000 (5000)	
	3F430	169 (4300)	90.4 (2300)	220.5 (5600)	204.1 (5185)	41.5 (1055)	57.9 (1470)	6/6	10000 (4500)	10000 (4500)	11000 (5000)	11000 (5000)	
	3F475	187 (4750)	95.7 (2435)	238.2 (6050)	221.9 (5635)	46.9 (1190)	63.2 (1605)	6/6	10000 (4500)	10000 (4500)	11000 (5000)	11000 (5000)	
	3F515	203 (5150)	100.2 (2550)	253.9 (6450)	237.6 (6035)	51.4 (1305)	67.7 (1720)	6/6	9600 (4300)	10000 (4500)	9800 (4450)	11000 (5000)	
	3F550	217 (5500)	108.1 (2750)	267.7 (6800)	251.4 (6385)	59.3 (1505)	75.6 (1920)	6/6	7000 (3150)	9700 (4350)	7100 (3200)	10800 (4900)	
3F600	236 (6000)	117.9 (3000)	287.4 (7300)	271.1 (6885)	69.1 (1755)	85.4 (2170)	6/6	5300 (2350)	9400 (4200)	5400 (2450)	9600 (4350)		

\*Overall Height - Fully Extended Without LBR, should be reduced by 1.2" to calculate PF100Y Two-Stage Masts (2W)

## STANDARD EQUIPMENT

- UniCarriers' own GCT TB45 LP or dual fuel, in-line, 6-cylinder industrial engine
- Computer controlled electronic engine system, with single-port fuel injection (LP) and multi-port injection (gas\*), providing low emission levels
- Engine/transmission protection and warning system
- Operator Presence System
- Full suspension seat with operator restraint system
- Horn and back-up alarm
- Cushioned floor mat
- Tilt-adjustable steering wheel
- Multi-function LCD:
  - Hour meter, Clock, Calendar & Operator PIN access
  - Onboard diagnostics and programmable service reminders
  - Warning lights & engine coolant temperature gauge
  - Air cleaner service indicator
  - Low engine oil pressure warning
  - Low coolant & brake fluid level warning indicators
  - Low fuel warning indicator & fuel gauge (Gasoline)
- Single speed powershift transmission with full floating powertrain
- Hydrostatic power steering
- Hydraulic boosted brakes
- Single lift/tilt hydraulic control lever
- High air intake system with large 7" cyclone air filter
- Overhead guard mounted LED headlights
- 5-piece reinforced overhead guard

## OPTIONAL EQUIPMENT

- High/Low travel speed control settings
- Power/Economy acceleration mode
- Two speed automatic transmission
- Separate lift and tilt hydraulic control levers
- Synchronized steering with spinner knob
- Swivel seat with rear overhead guard mounted assist grip with horn button
- Solid or dual drive pneumatic tires
- Anti-Dust, Low Noise, or Corrosion Resistance packages
- Tilt cylinder boot covers
- Vertical exhaust (not available on LPS models)
- Radiator screen
- Air intake pre-cleaner
- Rear LED combination light package
- Rotating beacon or strobe light
- Rear LED work light
- Low overhead guard (88.5" high)

\* on Dual Fuel Models

## OPERATOR COMFORT & CONTROL

A spacious operator compartment provides generous foot, leg and head room for a variety of driver sizes. A standard full suspension seat with soft touch arm pads and back angle adjustment provides maximum operator comfort. Its low profile design offers ample head clearance, while front to back travel adjustment allows a comfortable, customized fit for nearly any operator height.

The Platinum G04's tilt-adjustable steering wheel helps the operator quickly find his or her ideal driving position, while its compact design offers enhanced control and handling. Hydrostatic power steering minimizes steer effort and operator fatigue. Hydraulic boosted brakes offer reduced pedal effort and improved brake durability. An optional swivel seat produces greater operator comfort and visibility while driving in reverse, and includes a rear assist grip with horn button to further enhance operator productivity. Automotive-style light and turn signal levers simplify repetitive actions allowing the operator to focus on the job. An optional auto tilt leveling system assists proper mast/fork positioning.

Enhanced comfort results from the Platinum G04 Series' Operator Comfort System, which includes a full suspension seat, cushion floor mat, pedals mounted to the chassis frame, and rubber shock absorbers located throughout the vehicle to reduce vibration from the engine and transmission to the operator. For additional vibration reduction, Platinum G04 Series models include an automotive-type floating powertrain design, which incorporates four rubber engine/transmission supports. The G04's chassis has been designed with a low center of gravity (CG), with the roll center of the rear axle mounted close to the CG, for enhanced stability.

The G04 features tandem hydraulic pumps, with one pump for lifting and one pump for the power steering and brake booster. A priority load sensing control valve allows the steering/brake pump to supply hydraulic oil to the lift system when not required for steering/braking.

## ENHANCED WORK ENVIRONMENT

Several standard features are included in the GO4 Series to deliver a more comfortable and productive work environment for the operator and those in the surrounding area.

UniCarriers' own GCT TB45 engine offers extremely low noise levels at the operator's ear during idle and at maximum travel speeds. An optional travel speed control feature is available to regulate high or low maximum travel speed settings, while the optional controlled acceleration's Economy Mode adjusts throttle sensitivity to increase fuel efficiency, extend drivetrain life and reduce excessive tire wear. Two-speed models feature an automatic transmission with reduced shift shock due to shortened shift time lag and utilization of an optimized shift schedule.

The GO4 Series' Operator Presence System, with seat-actuated power interrupt, incorporates a mast-lock which automatically locks lift and tilt operations when the operator leaves the seat, and a return to neutral feature to minimize forklift movement if the operator leaves the seat while the lift truck is still in gear. This presence system also includes audible and visual warnings if either the seat belt is not engaged, or when the parking brake has not been applied prior to the operator exiting the compartment.

For easy entry/exit from either side, welded metal assist grips, combined with a replaceable metal traction plate bolted to the truck's wide, low entry step, provide the operator with sure, comfortable footing and grip for this often repeated task.



## DURABLE DESIGN FEATURES

The G04 Series is built for rugged applications, incorporating a robust mast, strong frame, thick steel fenders, and 5-ton truck drive and steer axles across all models.

The G04's superior cooling system consists of an oversized fan and wide cooling outlet, for enhanced airflow, and a heavy-duty radiator, with transmission oil cooler, rubber mounted to reduce flexing and absorb vibration for enhanced reliability. Its improved cooling capacity translates into dependable cooling efficiency under heavy usage or high ambient temperatures. A heavy-duty steer axle, cast for improved axle strength, protects the steer cylinder from damage, while steer cylinder boot covers keep out dirt and debris. The rear axle ball joints, with dust covers for protection against dirt, include grease fittings for easy lubrication to provide longer life and steering ease.

Lift cylinders include oil return piping for reduced heat generation. The counterweight is designed to deflect cooling airflow down and away from the truck, and it features a built-in radiator protection bar.

IP55 & IP65 rated control modules, combined with a wiring harness with sealed connectors, deliver protection against dirt and corrosion.

## EASE OF MAINTENANCE

Tilt cylinders can be greased without removing any body panels. One bolt removal allows the two-piece diamond tread floorboard to be lifted off, promoting simple access to hydraulic components. Detachable side panels and a wide-open clamshell hood provide a roomy area for service technicians to perform their tasks. The five-piece reinforced overhead guard simplifies replacement of individual components if necessary, saving time and money. An access door in the floor board allows for quick and easy brake fluid checks.

A multi-function LCD display includes on-board diagnostics to keep service time low, with a programmable service reminder in order to stay current with periodic maintenance needs. Its display design provides the operator with excellent visibility and understanding of indicator lights.

## ELECTRONIC CONTROLLED ENGINE TECHNOLOGY

The GCT electronic fuel injected system analyzes engine performance parameters and optimizes engine operation, resulting in enhanced productivity and lower fuel consumption. This system includes three main components: Engine Control Module (ECM), Vehicle Control Module (VCM), and Multi-function LCD.

The ECM responds to sensor input to control basic engine related functions, such as proper air/fuel ratio, torque and speed, based on the requirements of the application. The VCM monitors a number of sensors to alert the operator of changing conditions via a full range of warning indicators located on the truck's LCD. All communication among these components occurs through a Controller Area Network (CAN) system.

The GCT industrial engine is specifically designed and tested for industrial applications in order to deliver high power and torque to meet the needs of the application. As an added safeguard for your investment, the G04 Series includes an engine and transmission protection and warning system to reduce engine rpm in the event of excessive heat generation or loss of engine oil.

## LOW EMISSION ENGINE

UniCarriers' global commitment to preserving and protecting the environment is evident in the our own TB45 low emission, 6-cylinder LPG or dual fuel (LP & Gasoline) industrial engine, offering improved fuel consumption. The combination of advanced engine technology results in high power and increased efficiency, with emission levels well below EPA and CARB requirements.



UniCarriersAmericas.com

SS-G04-TB45 05-2018 Printed in U.S.A.

UniCarriers® is a registered trademark of UniCarriers Corporation. Platinum® is a registered trademark of UniCarriers Americas. UniCarriers Americas Corporation reserves the right to make product changes relating to colors, equipment, specifications or available options without notice. For more information, contact your UniCarriers representative.



# UNICARRIERS<sup>®</sup>

## □ FORKLIFT □

# Platinum GO4 Diesel



Engine Powered Forklifts

EPA Tier 4 Diesel

8,000 - 11,000 lbs. Capacities | Pneumatic Tire



# S P E C I F I C A T I O N S

## MAIN TRUCK SPECIFICATIONS

CHARACTERISTICS	1	Manufacturer's Name		UniCarriers		UniCarriers		
	2	Model	Model designation	1 Spd / 2 Spd	PF80YD	PF80HD	PF90YD	PF90HD
	3		Long model code	1 Spd / 2 Spd	MD1F4A35V	MD1F4F35V	MD1F4A40V	MD1F4F40V
	4	Power Type			Diesel		Diesel	
	5	Rated Load Capacity	lb (kg)		8000 (3500)		9000 (4000)	
	6	Load Center	Distance	in (mm)	24 (600)		24 (600)	
	7	Operator Orientation			Sit		Sit	
DIMENSIONS	8	Tire Type	Front & rear		Pneumatic		Pneumatic	
	9	Wheels	Number - front/rear(x=driven)		2x / 2		2x / 2	
	10	Mast	Maximum fork height	in (mm)	130 (3300)		130 (3300)	
	11		Mast lowered (OHL)	in (mm)	90.4 (2295)		90.4 (2295)	
	12		Mast extended with LBR	in (mm)	181.1 (4600)		181.1 (4600)	
	13		Standard freelif	in (mm)	5.1 (130)		5.1 (130)	
	14	Forks	Length x thickness x width	in (mm)	48 x 2 x 6 (1220 x 50 x 150)		48 x 2 x 6 (1220 x 50 x 150)	
	15	Tilt Angle	Standard mast - fwd/back	degree	6 / 12		6 / 12	
	16	Overall Dimensions	Length (to face of forks)	in (mm)	121.8 (3095)		123.1 (3130)	
	17		Height - top of OHG	in (mm)	92.5 (2350)		92.5 (2350)	
	18		Height - top of standard LBR	in (mm)	48.0 (1220)		48.0 (1220)	
	19		Width - standard carriage	in (mm)	47.2 (1200)		47.2 (1200)	
	20	Overall Width	Width - single tire / single wide tire	in (mm)	58.7 (1490) / 58.7 (1490)		— / 58.7 (1490)	
	21		Width - dual tire / dual wide tire	in (mm)	69.9 (1775) / 77.6 (1975)		69.9 (1775) / 77.6 (1975)	
	22	Overhang	Front / rear	in (mm)	22.0 (560) / 21.1 (535)		22.0 (560) / 22.4 (570)	
	23	Turning Radius	Minimum outside	in (mm)	107.1 (2720)		108.3 (2755)	
	24	Min Right Angle Stack	Add load length & clearance	in (mm)	129.1 (3280)		130.3 (3315)	
PERFORMANCE	25	Travel Speed Forward	Maximum - loaded / unloaded	mph (km/h)	11.2 (18) / 12.1 (19.5)	14.6 (23.5) / 15.2 (24.5)	11.2 (18) / 12.1 (19.5)	14.6 (23.5) / 15.2 (24.5)
	26	Lifting Speed	Maximum - loaded / unloaded	fpm (mm/sec)	98.4 (500) / 102.4 (520)		98.4 (500) / 102.4 (520)	
	27	Lowering Speed	Maximum - loaded / unloaded	fpm (mm/sec)	98.4 (500) / 98.4 (500)		98.4 (500) / 98.4 (500)	
	28	Drawbar Pull Maximum	Full load - at 1 mph	lb (N)	6600 (29350)	7255 (32280)	6800 (30200)	7465 (33220)
	29		No load - at 1 mph	lb (N)	5225 (23220)	5740 (25540)	5420 (24070)	5950 (26470)
	30	Gradeability Maximum	Full load / no load - at 1 mph	%	26 / 26		24 / 24	
WEIGHT	31	Truck Weight	No load - standard truck	lb (kg)	12655 (5740)	12720 (5770)	13215 (5995)	13285 (6025)
	32	Weight Distribution	Front axle - empty	lb (kg)	5535 (2510)	5565 (2525)	5555 (2520)	5600 (2540)
	33		Rear axle - empty	lb (kg)	7120 (3230)	7155 (3245)	7660 (3475)	7685 (3485)
	34		Front axle - with rated load	lb (kg)	18010 (8040)	18040 (8055)	19670 (8840)	19715 (8860)
	35		Rear axle - with rated load	lb (kg)	2645 (1200)	2680 (1215)	2545 (1155)	2570 (1165)
CHASSIS & WHEELS	36	Wheelbase		in (mm)	78.5 (2000)		78.5 (2000)	
	37	Tire Size	Front Tread - single / single wide		8.25 x 15-12PR / 300 x 15-18PR		— / 300 x 15-18PR	
	38		Front Tread - dual / dual wide		7.50 x 16-12PR / 8.25 x 15-12PR		7.50 x 16-12PR / 8.25 x 15-12PR	
	39		Rear Tread		7.00 x 12-12PR		7.00 x 12-12PR	
	40	Tread - Center of Tire	Front Tread - single / single wide	in (mm)	49.2 (1250) / 46.5 (1180)		— / 46.5 (1180)	
	41		Front Tread - dual / dual wide	in (mm)	51.5 (1310) / 56.9 (1445)		51.5 (1310) / 56.9 (1445)	
	42		Rear Tread	in (mm)	46.5 (1180)		46.5 (1180)	
	43	Seat Height		in (mm)	46.0 (1170)		46.0 (1170)	
	44	Headroom	SIP to bottom of OHG	in (mm)	40 (1015)		40 (1015)	
	45	Counterweight Height		in (mm)	50.2 (1275)		50.2 (1275)	
	46	Step Height		in (mm)	18.7 (475)		18.7 (475)	
	47	Floor Height		in (mm)	31.3 (795)		31.3 (795)	
	48	Ground Clearance	Under mast / power unit / frame	in (mm)	5.7 (145) / 6.7 (170) / 8.9 (225)		5.7 (145) / 6.7 (170) / 8.9 (225)	
	49	Service Brake	Type		Foot, Hydraulic Boost		Foot, Hydraulic Boost	
	50	Parking Brake	Type		Hand, Mechanical		Hand, Mechanical	
DRIVE LINE	51	Steering	Type		Hydrostatic, Power		Hydrostatic, Power	
	52	Engine	Model		GCT ZD30		GCT ZD30	
	53	Rated Output	SAE gross - LP, Diesel	hp(kW)@rpm	73.7 (55) @ 2400		73.7 (55) @ 2400	
	54	Rated Torque	SAE gross - LP, Diesel	ft-lb(Nm)@rpm	181 (245) @ 1800		181 (245) @ 1800	
	55	Displacement		cu in (cm <sup>3</sup> )	180 (2950)		180 (2950)	
	56	Transmission Speeds	Automatic powershift type		1 fwd / 1 rev	2 fwd / 1 rev	1 fwd / 1 rev	2 fwd / 1 rev



## MAIN TRUCK SPECIFICATIONS

CHARACTERISTICS	1	Manufacturer's Name		UniCarriers		UniCarriers			
	2	Model	Model designation	1 Spd / 2 Spd	PF100YD	PF100HD	PF110YD	PFD110HD	
	3		Long model code	1 Spd / 2 Spd	MD1F4A45V	MD1F4F45V	MDG1F4A50V	MDG1F4F50V	
CHARACTERISTICS	4	Power Type			Diesel		Diesel		
	5	Rated Load Capacity		lb (kg)	10000 (4500)		11000 (5000)		
	6	Load Center	Distance	in (mm)	24 (600)		24 (600)		
	7	Operator Orientation			Sit		Sit		
	DIMENSIONS	8	Tire Type	Front & rear		Pneumatic		Pneumatic	
		9	Wheels	Number - front/rear(x=driven)		2x / 2		2x / 2	
		10	Mast	Maximum fork height	in (mm)	130 (3300)		130 (3300)	
11			Mast lowered (OHL)	in (mm)	90.4 (2295)		90.4 (2295)		
12			Mast extended with LBR	in (mm)	181.1 (4600)		181.1 (4600)		
13			Standard freelif	in (mm)	5.1 (130)		5.1 (130)		
14		Forks	Length x thickness x width	in (mm)	48 x 2 x 6 (1220 x 50 x 150)		48 x 2 x 6 (1220 x 50 x 150)		
15		Tilt Angle	Standard mast - fwd/back	degree	6 / 12		6 / 12		
16		Overall Dimensions	Length (to face of forks)	in (mm)	126.3 (3210)		131.5 (3340)		
17			Height - top of OHG	in (mm)	92.5 (2350)		92.5 (2350)		
18			Height - top of standard LBR	in (mm)	48.0 (1220)		48.0 (1220)		
19			Width - standard carriage	in (mm)	47.2 (1200)		47.2 (1200)		
20		Overall Width	Width - single wide tire	in (mm)	58.7 (1490)		58.7 (1490)		
21			Width - dual tire / dual wide tire	in (mm)	69.9 (1775) / 77.6 (1975)		69.9 (1775) / 77.6 (1975)		
22		Overhang	Front / rear	in (mm)	23.1 (587) / 24.5 (622)		23.5 (597) / 23.3 (593)		
23		Turning Radius	Minimum outside	in (mm)	110.2 (2800)		115.6 (2940)		
24		Min Right Angle Stack	Add load length & clearance	in (mm)	133.3 (3387)		139.1 (3537)		
PERFORMANCE		25	Travel Speed Forward	Maximum - loaded / unloaded	mph (km/h)	11.2 (18) / 12.1 (19.5)	14.6 (23.5) / 15.2 (24.5)	11.2 (18) / 12.1 (19.5)	14.6 (23.5) / 15.2 (24.5)
		26	Lifting Speed	Maximum - loaded / unloaded	fpm (mm/sec)	84.6 (430) / 88.6 (450)		82.7 (420) / 88.6 (440)	
		27	Lowering Speed	Maximum - loaded / unloaded	fpm (mm/sec)	88.6 (450) / 88.6 (450)		88.6 (450) / 88.6 (450)	
		28	Drawbar Pull Maximum	Full load - at 1 mph	lb (N)	6980 (31050)	7675 (34150)	7171 (31900)	7885 (35090)
		29		No load - at 1 mph	lb (N)	5602 (24920)	6160 (27410)	5793 (25770)	6370 (28340)
		30	Gradeability Maximum	Full load / no load - at 1 mph	%	21 / 21		19 / 19	
WEIGHT		31	Truck Weight	No load - standard truck	lb (kg)	14905 (6760)	14970 (6790)	16115 (7310)	16185 (7340)
	32	Weight Distribution	Front axle - empty	lb (kg)	5920 (2685)	5955 (2700)	6525 (2960)	6560 (2975)	
	33		Rear axle - empty	lb (kg)	8985 (4075)	9015 (4090)	9590 (4350)	9625 (4365)	
	34		Front axle - with rated load	lb (kg)	21805 (9855)	21840 (9870)	23665 (10745)	23700 (10760)	
	35		Rear axle - with rated load	lb (kg)	3100 (1405)	3130 (1420)	3450 (1565)	3485 (1580)	
CHASSIS & WHEELS	36	Wheelbase		in (mm)	78.5 (2000)		84.5 (2150)		
	37	Tire Size	Front Tread - single wide		300 x 15-18PR		300 x 15-18PR		
	38		Front Tread - dual / dual wide		7.50 x 16-12PR / 8.25 x 15-12PR		7.50 x 16-12PR / 8.25 x 15-12PR		
	39		Rear Tread		7.00 x 12-12PR		7.00 x 12-12PR		
	40	Tread - Center of Tire	Front Tread - single / single wide	in (mm)	- / 46.5 (1180)		- / 46.5 (1180)		
	41		Front Tread - dual / dual wide	in (mm)	51.5 (1310) / 56.9 (1445)		51.5 (1310) / 56.9 (1445)		
	42		Rear Tread	in (mm)	46.5 (1180)		46.5 (1180)		
	43	Seat Height		in (mm)	46.0 (1170)		46.0 (1170)		
	44	Headroom	SIP to bottom of OHG	in (mm)	40 (1015)		40 (1015)		
	45	Counterweight Height		in (mm)	50.2 (1275)		50.2 (1275)		
	46	Step Height		in (mm)	18.7 (475)		18.7 (475)		
	47	Floor Height		in (mm)	31.3 (795)		31.3 (795)		
	48	Ground Clearance	Under mast / power unit / frame	in (mm)	5.7 (145) / 6.7 (170) / 8.9 (225)		5.7 (145) / 6.7 (170) / 8.9 (225)		
	49	Service Brake	Type		Foot, Hydraulic Boost		Foot, Hydraulic Boost		
	50	Parking Brake	Type		Hand, Mechanical		Hand, Mechanical		
	DRIVE LINE	51	Steering	Type		Hydrostatic, Power		Hydrostatic, Power	
52		Engine	Model		GCT ZD30		GCT ZD30		
53		Rated Output	SAE gross - LP, Diesel	hp(kW)@rpm	73.7 (55) @ 2400		73.7 (55) @ 2400		
54		Rated Torque	SAE gross - LP, Diesel	ft-lb(Nm)@rpm	181 (245) @ 1800		181 (245) @ 1800		
55		Displacement		cu in (cm <sup>3</sup> )	180 (2950)		180 (2950)		
56		Transmission Speeds	Automatic powershift type		1 fwd / 1 rev	2 fwd / 1 rev	1 fwd / 1 rev	2 fwd / 1 rev	

## DIMENSIONS

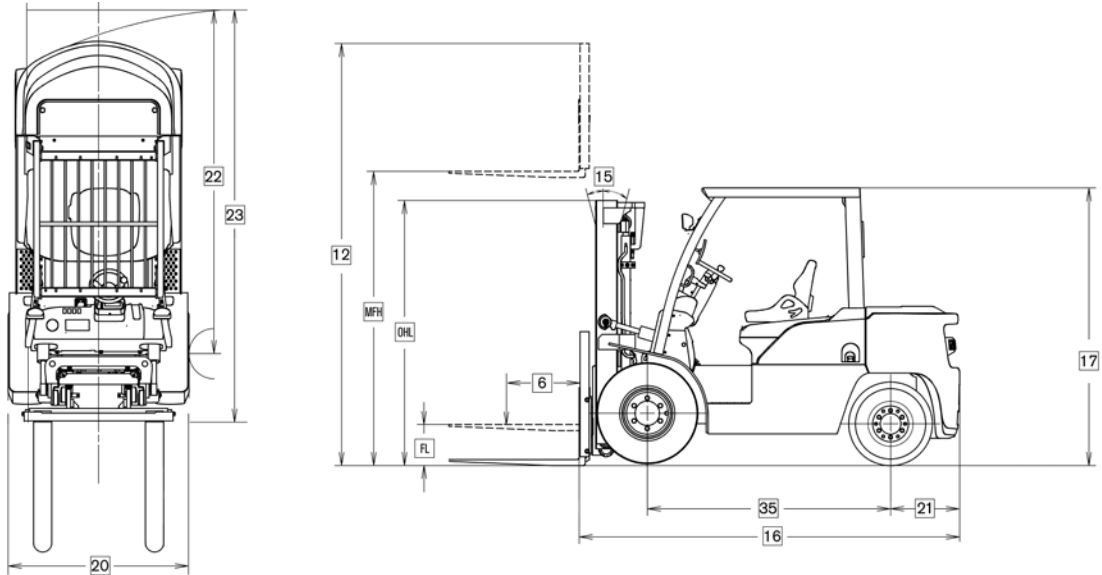

## MAST SPECIFICATIONS & RATED CAPACITIES

Mast Type	Mast Name	Maximum Fork Height	Overall Height				Free Lift		Tilt Angle	Rated Capacity at 24" Load Center			
			Lowered	Fully Extended		With LBR	Without LBR	Fwd/Bkwd		PF80YD/HD		PF90YD/HD	
				in (mm)	in (mm)				With LBR	Without LBR	Single Drive	Dual Drive	Single Drive
TWO STAGE (Wide view)	2W300	118 (3000)	84.4 (2150)	169.3 (4300)	151.0 (3835)	5.1 (130)	5.1 (130)	6/12	8000 (3500)	8000 (3500)	9000 (4000)	9000 (4000)	
	2W330	130 (3300)	90.4 (2300)	181.1 (4600)	162.8 (4135)	5.1 (130)	5.1 (130)	6/12	8000 (3500)	8000 (3500)	9000 (4000)	9000 (4000)	
	2W350	138 (3500)	95.7 (2435)	189.0 (4800)	170.7 (4335)	5.1 (130)	5.1 (130)	6/12	8000 (3500)	8000 (3500)	9000 (4000)	9000 (4000)	
	2W370	146 (3700)	100.2 (2550)	196.9 (5000)	178.5 (4535)	5.1 (130)	5.1 (130)	6/12	8000 (3500)	8000 (3500)	9000 (4000)	9000 (4000)	
	2W400	157 (4000)	108.1 (2750)	208.7 (5300)	190.4 (4835)	5.1 (130)	5.1 (130)	6/12	8000 (3500)	8000 (3500)	9000 (4000)	9000 (4000)	
	2W450	177 (4500)	117.9 (3000)	228.3 (5800)	210.0 (5335)	5.1 (130)	5.1 (130)	6/6	8000 (3500)	8000 (3500)	9000 (4000)	9000 (4000)	
THREE STAGE (Full free)	2W500	197 (5000)	127.8 (3250)	248.0 (6300)	229.7 (5835)	5.1 (130)	5.1 (130)	6/6	8000 (3500)	8000 (3500)	9000 (4000)	9000 (4000)	
	3F385	152 (3850)	78.5 (2000)	202.8 (5150)	186.0 (4725)	29.5 (750)	46.3 (1175)	6/6	8000 (3500)	8000 (3500)	9000 (4000)	9000 (4000)	
	3F430	169 (4300)	84.4 (2150)	220.5 (5600)	203.7 (4175)	35.4 (900)	52.2 (1325)	6/6	8000 (3500)	8000 (3500)	9000 (4000)	9000 (4000)	
	3F475	187 (4750)	90.4 (2300)	238.2 (6050)	221.5 (5625)	41.3 (1050)	58.1 (1475)	6/6	8000 (3500)	8000 (3500)	9000 (4000)	9000 (4000)	
	3F515	203 (5150)	95.7 (2435)	253.9 (6450)	237.2 (6025)	46.7 (1185)	63.4 (1610)	6/6	7800 (3400)	8000 (3500)	8700 (3850)	8700 (3850)	
	3F550	217 (5500)	100.2 (2550)	267.7 (6800)	251.0 (6375)	51.2 (1300)	67.9 (1725)	6/6	5300 (2300)	7600 (3300)	6900 (3050)	8500 (3750)	
3F600	236 (6000)	108.1 (2750)	287.4 (7300)	270.7 (6875)	59.1 (1500)	75.8 (1925)	6/6	4000 (1750)	7200 (3150)	5200 (2300)	8300 (3650)		

## MAST SPECIFICATIONS & RATED CAPACITIES

Mast Type	Mast Name	Maximum Fork Height	Overall Height				Free Lift		Tilt Angle	Rated Capacity at 24" Load Center			
			Lowered	Fully Extended		With LBR	Without LBR	Fwd/Bkwd		PF100YD/HD		PFD110YD/HD	
				in (mm)	in (mm)				With LBR	Without LBR*	Single Drive	Dual Drive	Single Drive
TWO STAGE (Wide view)	2W300	118 (3000)	84.4 (2150)	169.3 (4300)	153.0 (3890)	6.9 (175)	6.9 (175)	6/12	10000 (4500)	10000 (4500)	11000 (5000)	11000 (5000)	
	2W330	130 (3300)	90.4 (2300)	181.1 (4600)	164.8 (4185)	6.9 (175)	6.9 (175)	6/12	10000 (4500)	10000 (4500)	11000 (5000)	11000 (5000)	
	2W350	138 (3500)	95.7 (2435)	189.0 (4800)	172.6 (4385)	6.9 (175)	6.9 (175)	6/12	10000 (4500)	10000 (4500)	11000 (5000)	11000 (5000)	
	2W370	146 (3700)	100.2 (2550)	196.9 (5000)	180.5 (4585)	6.9 (175)	6.9 (175)	6/12	10000 (4500)	10000 (4500)	11000 (5000)	11000 (5000)	
	2W400	157 (4000)	108.1 (2750)	208.7 (5300)	192.3 (4885)	6.9 (175)	6.9 (175)	6/12	10000 (4500)	10000 (4500)	11000 (5000)	11000 (5000)	
	2W450	177 (4500)	117.9 (3000)	228.3 (5800)	212.0 (5385)	6.9 (175)	6.9 (175)	6/6	10000 (4500)	10000 (4500)	11000 (5000)	11000 (5000)	
THREE STAGE (Full free)	2W500	197 (5000)	127.8 (3250)	248.0 (6300)	231.7 (5885)	6.9 (175)	6.9 (175)	6/6	10000 (4500)	10000 (4500)	11000 (5000)	11000 (5000)	
	3F385	152 (3850)	84.4 (2150)	202.8 (5150)	186.4 (4735)	35.6 (905)	52.0 (1320)	6/6	10000 (4500)	10000 (4500)	11000 (5000)	11000 (5000)	
	3F430	169 (4300)	90.4 (2300)	220.5 (5600)	204.1 (5185)	41.5 (1055)	57.9 (1470)	6/6	10000 (4500)	10000 (4500)	11000 (5000)	11000 (5000)	
	3F475	187 (4750)	95.7 (2435)	238.2 (6050)	221.9 (5635)	46.9 (1190)	63.2 (1605)	6/6	10000 (4500)	10000 (4500)	11000 (5000)	11000 (5000)	
	3F515	203 (5150)	100.2 (2550)	253.9 (6450)	237.6 (6035)	51.4 (1305)	67.7 (1720)	6/6	9600 (4300)	10000 (4500)	9800 (4450)	11000 (5000)	
	3F550	217 (5500)	108.1 (2750)	267.7 (6800)	251.4 (6385)	59.3 (1505)	75.6 (1920)	6/6	7000 (3150)	9700 (4350)	7100 (3200)	10800 (4900)	
3F600	236 (6000)	117.9 (3000)	287.4 (7300)	271.1 (6885)	69.1 (1755)	85.4 (2170)	6/6	5300 (2350)	9400 (4200)	5400 (2450)	9600 (4350)		

\* Overall Height - Fully Extended Without LBR, should be reduced by 1.2" to calculate FD45-A2 Two-Stage Masts (2W)

## STANDARD EQUIPMENT

- UniCarriers' own GCT ZD30 low emission, 4-cylinder, 3.0L diesel industrial engine
- 'Advanced Turbo Diesel' (ATD) engine design
- Computer controlled electronic engine system, with common rail fuel injection and turbocharger
- Cooled Exhaust Gas Recirculation (EGR) and Diesel Oxidation Catalyst (DOC)
- Engine/transmission protection and warning system
- Operator Presence System
- Full suspension seat with operator restraint system
- Horn and back-up alarm
- Cushioned floor mat
- Tilt-adjustable steering wheel
- Multi-function LCD:
  - Hour meter, Clock, Calendar & Operator PIN access
  - Onboard diagnostics and programmable service reminders
  - Warning lights & engine coolant temperature gauge
  - Air cleaner service indicator
  - Low engine oil pressure warning
  - Low coolant & brake fluid level warning indicators
  - Low fuel warning indicator & fuel gauge
- Single speed powershift transmission with full floating powertrain
- Hydrostatic power steering
- Hydraulic boosted brakes
- Single lift/tilt hydraulic control lever
- High air intake system with large 7" cyclone air filter
- Overhead guard mounted LED headlights
- 5-piece reinforced overhead guard
- High/Low travel speed control settings
- Power/Economy acceleration mode

## OPTIONAL EQUIPMENT

- Two speed automatic transmission
- Separate lift & tilt hydraulic control levers
- Synchronized steering with spinner knob
- Swivel seat with rear OHG mounted assist grip with horn button
- Solid or dual drive pneumatic tires
- Anti-Dust, Low Noise, or Corrosion Resistance packages
- Tilt cylinder boot covers
- Vertical exhaust
- Radiator screen
- Air intake pre-cleaner
- Rear LED combination light package
- Rotating beacon or strobe light
- Rear LED work light
- Low overhead guard (88.5" high)

## OPERATOR COMFORT & CONTROL

A spacious operator compartment provides generous foot, leg and head room for a variety of driver sizes. A standard full suspension seat with soft touch arm pads and back angle adjustment provides maximum operator comfort. Its low profile design offers ample head clearance, while front to back travel adjustment allows a comfortable, customized fit for nearly any operator height.

The Platinum G04's tilt-adjustable steering wheel helps the operator quickly find his or her ideal driving position, while its compact design offers enhanced control and handling. Hydrostatic power steering minimizes steer effort and operator fatigue. Hydraulic boosted brakes offer reduced pedal effort and improved brake durability. An optional swivel seat produces greater operator comfort and visibility while driving in reverse, and includes a rear assist grip with horn button to further enhance operator productivity. Automotive-style light and turn signal levers simplify repetitive actions allowing the operator to focus on the job. An optional auto tilt leveling system assists proper mast/fork positioning.

Enhanced comfort results from the Platinum G04 Series' Operator Comfort System, which includes a full suspension seat, cushion floor mat, pedals mounted to the chassis frame, and rubber shock absorbers located throughout the vehicle to reduce vibration from the engine and transmission to the operator. For additional vibration reduction, Platinum G04 Series models include an automotive-type floating powertrain design, which incorporates four rubber engine/transmission supports. The G04's chassis has been designed with a low center of gravity (CG), with the roll center of the rear axle mounted close to the CG, for enhanced stability.

The G04 features tandem hydraulic pumps, with one pump for lifting and one pump for the power steering and brake booster. A priority load sensing control valve allows the steering/brake pump to supply hydraulic oil to the lift system when not required for steering/braking.

## ENHANCED WORK ENVIRONMENT

Several standard features are included in the GO4 Series to deliver a more comfortable and productive work environment for the operator and those in the surrounding area.

UniCarriers' own GCT ZD30 engine offers extremely low noise levels at the operator's ear during idle and at maximum travel speeds. A travel speed control feature is available to regulate high or low maximum travel speed settings, while the controlled acceleration's Economy Mode adjusts throttle sensitivity to increase fuel efficiency, extend drivetrain life and reduce excessive tire wear. Two-speed models feature an automatic transmission with reduced shift shock due to shortened shift time lag and utilization of an optimized shift schedule.

The GO4 Series' Operator Presence System, with seat-actuated power interrupt, incorporates a mast-lock which automatically locks lift and tilt operations when the operator leaves the seat, and a return to neutral feature to minimize forklift movement if the operator leaves the seat while the lift truck is still in gear. This presence system also includes audible and visual warnings if either the seat belt is not engaged, or when the parking brake has not been applied prior to the operator exiting the compartment.

For easy entry/exit from either side, welded metal assist grips, combined with a replaceable metal traction plate bolted to the truck's wide, low entry step, provide the operator with sure, comfortable footing and grip for this often repeated task.

## DURABLE DESIGN FEATURES

The G04 Series is built for rugged applications, incorporating a robust mast, strong frame, thick steel fenders, and 5-ton truck drive and steer axles across all models.

The G04's superior cooling system consists of an oversized fan and wide cooling outlet, for enhanced airflow, and a heavy-duty radiator, with transmission oil cooler, rubber mounted to reduce flexing and absorb vibration for enhanced reliability. Its improved cooling capacity translates into dependable cooling efficiency under heavy usage or high ambient temperatures. A heavy-duty steer axle, cast for improved axle strength, protects the steer cylinder from damage, while steer cylinder boot covers keep out dirt and debris. The rear axle ball joints, with dust covers for protection against dirt, include grease fittings for easy lubrication to provide longer life and steering ease.

Lift cylinders include oil return piping for reduced heat generation. The counterweight is designed to deflect cooling airflow down and away from the truck, and it features a built-in radiator protection bar.

IP55 & IP65 rated control modules, combined with a wiring harness with sealed connectors, deliver protection against dirt and corrosion.

## EASE OF MAINTENANCE

Tilt cylinders can be greased without removing any body panels. One bolt removal allows the two-piece diamond tread floorboard to be lifted off, promoting simple access to hydraulic components. Detachable side panels and a wide-open clamshell hood provide a roomy area for service technicians to perform their tasks. The five-piece reinforced overhead guard simplifies replacement of individual components if necessary, saving time and money. An access door in the floor board allows for quick and easy brake fluid checks.

A multi-function LCD display includes on-board diagnostics to keep service time low, with a programmable service reminder in order to stay current with periodic maintenance needs. Its display design provides the operator with excellent visibility and understanding of indicator lights.

## ELECTRONIC CONTROLLED ENGINE TECHNOLOGY

The ZD30 'Advanced Turbo Diesel' (ATD) electronic fuel injected engine analyzes engine performance parameters and optimizes engine operation, resulting in enhanced productivity and lower fuel consumption. This system includes three main components: Engine Control Module (ECM), Vehicle Control Module (VCM), and Multi-function LCD Display.

The ECM responds to sensor input to control basic engine related functions, such as proper air/fuel ratio, turbo boost pressure, torque and speed, based on the requirements of the application. The VCM monitors a number of sensors to alert the operator of changing conditions via a full range of warning indicators located on the truck's LCD display. All communication among these components occurs through a Controller Area Network (CAN) system.

The ZD30 industrial engine is specifically designed and tested for industrial applications in order to deliver the power and torque to meet the needs of the application. As an added safeguard for your investment, the GO4 Series includes an engine and transmission protection and warning system to reduce engine rpm in the event of excessive heat generation or loss of engine oil.

## LOW EMISSION DIESEL ENGINE

UniCarriers' global commitment to preserving and protecting the environment is evident in our own GCT ZD30 low emission, 4-cylinder diesel industrial engine, offering improved fuel consumption and near elimination of particulate matter. The combination of advanced engine technology—electronic fuel injection, turbo charger, cooled exhaust gas recirculation, and diesel oxidation catalyst—results in high power and increased efficiency, with emission levels well below EPA Tier 4 requirements. The ZD30 provides low emissions without using a Diesel Particulate Filter (DPF), so regeneration is not necessary. It also includes an electronic controlled Quick Glow system for dependable cold weather starting.



UniCarriersAmericas.com

SS-G04-ZD30 MFL4 05-2018 Printed in U.S.A.

UniCarriers® is a registered trademark of UniCarriers Corporation. Platinum® is a registered trademark of UniCarriers Americas. UniCarriers Americas Corporation reserves the right to make product changes relating to colors, equipment, specifications or available options without notice. For more information, contact your UniCarriers representative.

