



HANGCHA

HC FORKLIFT AMERICA CORPORATION

Company address:

10405-A Granite Street
Charlotte, NC 28273

Toll Free: (888) 652-8395

Phone: (980) 888-8335

Fax: (980) 888-8336

america@hcforklift.com
www.hcforkliftamerica.com



2020/14/PERSONAL/COPYRIGHT 2020/12

HANGCHA GROUP CO., LTD. reserves the right to make any changes without notice concerning colors, equipment, or specifications detailed in this brochure, or to discontinue individual models. The colors of trucks, delivered may differ slightly from those in brochures.



XF Series LPG, Dual Fuel, & Diesel Pneumatic Tire Forklift

with capacities of 3,000 to 7,000lbs

Making Material Handling Easier
SINCE 1956



Smart Simple Solid

Over 40 years of building forklifts have culminated in the XF series from Hangcha Group. This experience, combined with the latest in forklift technology, the result is a line of forklifts that are efficient, environmentally conscious, comfortable, reliable, and safe. The XF Series represents the true do it all forklift from Hangcha Group.



GCT K25/K21 Engine



North American EPA Certified Engines

The GCT K21/25 engines comply with the North American EPA emissions standards. Although they meet these standards, they still have the power and torque to get the job done. These engines are also electronically controlled to increase the fuel economy and the reliability of the trucks.

Kubota V2607 Diesel Engine

An Efficient & Reliable Solution

TIER 4F

Hangcha uses the powerful Kubota diesel engine in our pneumatic tire forklifts. The Kubota engine is Tier 4F compliant. The engine uses common rail fuel systems, diesel oxidation catalysts (DOC), and diesel particulate filters (DPF) to meet the Tier 4F compliance. This engine helps the Hangcha forklifts maximize their efficiency and reliability for the end-user.

KUBOTA V2607-CR-E5B

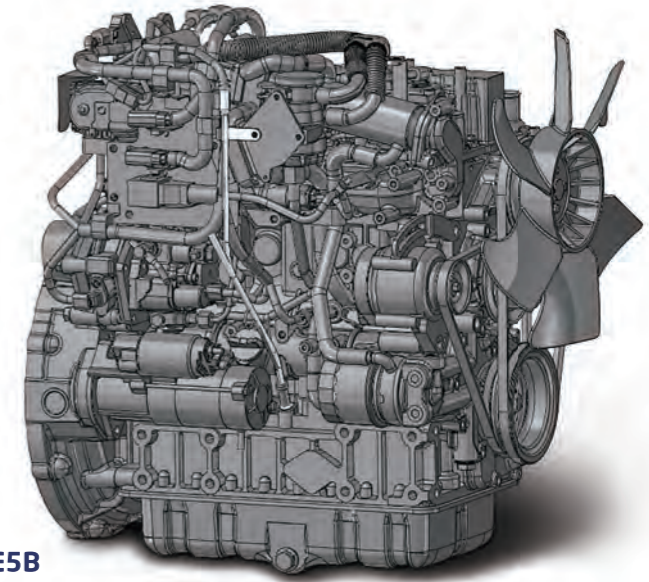

Comfortable Operation



In developing the XF Series, comfort and ease of operation were carefully considered. For example, vibration levels were improved by adding compound engine dampers and full-floating powertrain mounts. Comfortable operating environments for operators also contribute to increased productivity.



The rubber damper between the frame and the steering axle, the compound engine damper, and the full floating powertrain achieves a flexible connection between the frame and the driving system. As a result, vibrations are significantly reduced to increase operator comfort.



The increased capacity exhaust muffler, intake, and noise shield technology significantly lower the forklift's noise levels.

1. The new relocated, easy-to-see LCD instrument display lets the operator check on all aspects of operational status with a glance.
2. The new automobile-style light/turn-signal stalk and the forward-reverse lever are ergonomically designed and arranged to improve comfort and productivity.
3. The small-diameter steering wheel, with tilt adjustment, provides an optimal driving position for the operator. The superior responsiveness of the steering wheel optimizes maneuverability even in narrow spaces.
4. The parking brake was developed to reduce the operational force by 30%.
5. The automobile-style suspended pedals provide a more ergonomic, operator centered experience.



Instrument Display

The instrument display consists of a 4" color LCD screen, four interactive buttons, and one CAN bus communication function. The communication protocol is compatible with CANopen and SAE J1939 standards.



Comfortable Operation

Optimal visibility in all directions creates the best conditions for relaxed and safe working. These conditions promote high productivity among the operators.



The foot space is now 90% wider to significantly reduce operator fatigue. The new wide, non-slip step makes getting in and out of the forklift safe and easy.

The easy-to-operate levers provide total load handling operation. The armrest is provided to reduce fatigue. The optional electro-hydraulic proportional control system gives the forklift the ability to make load handling more sensitive and precise.

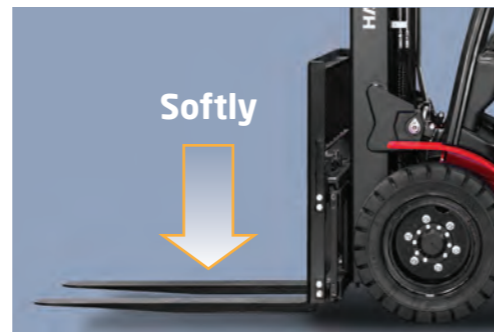

In addition to the soft landing system, the soft lifting system is adopted (front lifting cylinders of the full free lift 2 & 3 stage masts). As a result, the noise and shock of the mast significantly decrease when lowering materials.



The front lifting cylinders were redesigned with a smaller outer diameter to give the operator superior forward visibility.

The mast also provides better forward visibility.

Reliability

By focusing on enhancing reliability and reducing downtime, the XF series is able to increase productivity for the end-users.



The new, full-floating, aluminum alloy transmission features excellent heat dissipation and thicker discs to meet the most demanding applications.



The new controller is integrated into all of the electrical components. It also features excellent durability in harsh temperatures, water, and vibrations. This promotes reliability in the most demanding operations.



The new stamped air cleaner features a tangential intake, double seal, and a safety filter. The air cleaner is durable, corrosion-free, and vibration-resistant. It also provides better filter efficiency and lowers intake resistance.



XF series features a rugged design, stamped frame, and an engine hood. The stamped instrument panel, overhead guard, and heavy profile rail mast combine to provide excellent structural rigidity to ensure outstanding reliability and stability in heavy-duty conditions.



The forklifts are equipped with large capacity aluminum radiators. These radiators have optimized heat dissipation channels to enhance cooling capabilities. This keeps the engine running reliably in heavy-duty applications.

Easy to Maintain



The XF series is designed to facilitate easy inspections and servicing. Easy maintenance reduces the amount of downtime cost of ownership.

The cover on the dash can be lifted to easily check the brake fluid.

The two-piece design makes the floorboard easy to lift and remove for access to the powertrain.

The easy-to-operate latch provides quick access to the engine compartment.

The radiator cover fasteners can be turned by hand easily to enable quick inspections or servicing.

Safety

A wide range of technology is applied to ensure absolute safety for both the operator and those in the vicinity.



There is a locking mechanism found on the engine hood, damper, and parking brake for the operator's safety.



An optional rear reverse grip with a horn button enhances operational safety while traveling in reverse.



1. The Operator Presence Sensing System (OPS) incorporates a lifting, tilting, and traveling stop function. When the operator leaves the seat, the system automatically locks the lifting/tilting functions and disables the forklift from traveling to ensure safety.
2. The throttling device locks the mast in place if there is a hydraulic failure. This adds to the operational safety of the truck.

Standard Configuration

Transmission	Steering	Chassis	Control	Hydraulic
<ul style="list-style-type: none"> / Floating Transmission / Oil Filter / Dipstick / Oil Cooler / Non-Asbestos Brakes 	<ul style="list-style-type: none"> / Full Hydraulic Power Steering / Smaller Diameter Steering Wheel / Adjustable Steering Wheel 	<ul style="list-style-type: none"> / Skidproof Pedal / Rubber Pedal / Engine Hood Spring 	<ul style="list-style-type: none"> / Power Steering / Suspended Pedal / Integrated Combination Switch / Mechanical Parking Brake 	<ul style="list-style-type: none"> / Dynamic Load Sensing Control Valve (Diesel IC) / Hydraulic Oil Filter / Hydraulic Oil Dipstick / Tilt Cylinder Self-Locking Valve
Truck	Power	Electronics	Mast	
<ul style="list-style-type: none"> / Traction Device / Operator Hand Grips / Standard Seat / Standard Overhead Guard / Waterproof Cover for the Overhead Guard / Back View Mirror / Air Pneumatic Tire / Tilt Cylinder Cover / Tilt Cylinder Boot 	<ul style="list-style-type: none"> / Large Capacity Aluminum Radiator / Little Tank / Whirlwind Air Cleaner / Safety Filter / Highly Efficient Intake / Highly Efficient Exhaust Muffler 	<ul style="list-style-type: none"> / LED Headlights / Highly Efficient LED Rear Lights / Service-Free Start Battery / Combination Controller / LCD Display / Neutral Switch / Time Meter / Fuel Gauge / Water Temperature Gauge / Pre-Heat Indicator / Charging Indicator / Engine Fuel Pressure Warning / Transmission Oil Pressure Warning / Horn / Reversing Buzzer / Cut off Switch / Strobe Light / Operator Presence Sensing System (OPS) 	<ul style="list-style-type: none"> / Standard Wide View Mast / Standard forks / Standard Fork Carriage / Standard Load Back Rest / Mast Speed Limiting Valve / Load Safety Valve / Soft Landing System / Soft Lifting System / Side Roller 	

Options

- / Full Cabin
- / Cabin Heater
- / Front Window with Wiper
- / Solid Pneumatic Tires
- / Non-Marking Tires
- / Full Suspension Seat
- / Fire Extinguisher
- / Tilt Cylinder Cover
- / Higher Overhead Guard
- / Rear Reverse Grip with Horn
- / Customized Paint Color
- / Tilt Cylinder Boot
- / Counterweight Grill
- / Pre-Cleaner
- / Radiator Screen
- / LPG Swing Out Metal Bracket
- / LPG Swing Down Metal Bracket
- / Auxiliary Hydraulic Valve
- / Electro-Hydraulic Proportional Control System
- / Return Oil Filter
- / Front Working Light
- / Rear Working Light
- / Specialty Forks
- / Wider Fork Carriage
- / Wider Load Backrest
- / Various Optional Attachments

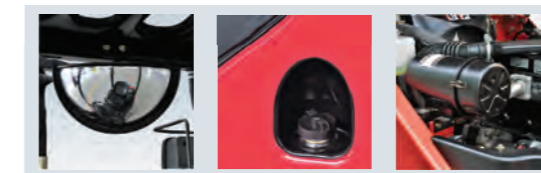

XF Series Pneumatic Forklift 3,000-7,000lb LP & Diesel Specification

		HANGCHA GROUP CO.,LTD.											
Distinguishing Marks	1.1	Manufacturer											
		HCF A Model	FP15	FP18	FP20	FD20	FP25	FD25	FP30	FD30	FP35	FD35	
	1.2	Manufacturer's Type Designation	CPYD15-XW81F	CPYD18-XW81F	CPYD20-XW71F	CPCD20-XW97F	CPYD25-XW71F	CPCD25-XW97F	CPYD30-XW71F	CPCD30-XW97F	CPYD35-XW71F	CPCD35-XW97F	
	1.3	Drive: electric (battery or mains), diesel, petrol, fuel gas	LPG	LPG	LPG	Diesel	LPG	Diesel	LPG	Diesel	LPG	Diesel	
	1.5	Rated Capacity/Rated Load	Q (lb)	3000	3500	4000	4000	5000	5000	6000	6000	7000	7000
	1.6	Load Centre Distance	c (in)	24	24	24	24	24	24	24	24	24	24
	1.8	Load Distance, centre of drive axle to fork	x (in)	16	16	18.3	18.3	18.3	18.3	18.9	18.9	19.1	19.1
		Rear Overhang	in	16	16.9	16.3	16.3	19.3	19.3	21.7	21.7	24.2	24.2
	1.9	Wheelbase	y (in)	58	58	65.0	65.0	65.0	65.0	66.9	66.9	66.9	66.9
Weight	2.1	Service Weight	lb	5830	5874	7491	7491	8283	8283	9570	9570	10351	10351
	2.2	Axle Loading, laden front/rear	lb	8052/1078	8789/1144	10351/1540	10351/1540	12045/1738	12045/1738	14190/1980	14190/1980	15961/2090	15961/2090
	2.3	Axle Loading, unladen front/rear	lb	2728/3102	2695/3388	3542/3949	3542/3949	3432/4851	3432/4851	3850/5720	3850/5720	3784/6567	3784/6567
Tires & Chassis	3.2	Tire Size, front		6.50-10-10PR	6.50-10-10PR	7.00-12-12PR	7.00-12-12PR	7.00-12-12PR	7.00-12-12PR	28×9-15-14PR	28×9-15-14PR	28×9-15-14PR	28×9-15-14PR
	3.3	Tire Size, rear		5.00-8-10PR	5.00-8-10PR	6.00-9-10PR	6.00-9-10PR	6.00-9-10PR	6.00-9-10PR	6.50-10-10PR	6.50-10-10PR	6.50-10-10PR	6.50-10-10PR
	3.6	Tread, front	b ₁₀ (in)	35.4	35.4	38.0	38.0	38.0	38.0	39.6	39.6	39.6	39.6
	3.7	Tread, rear	b ₁₁ (in)	36.2	36.2	38.3	38.3	38.3	38.3	38.4	38.4	38.4	38.4
Dimensions	4.1	Tilt of Mast/Fork Carriage Forward/Backward	α/β(°)	6/12	6/12	6/12	6/12	6/12	6/12	6/12	6/12	6/12	6/12
	4.2	Height, mast lowered	h ₁ (in)	78.5	78.5	80.1	80.1	80.1	80.1	80.7	80.7	85.2	85.2
	4.3	Free Lift	h ₂ (in)	6.1	6.1	5.5	5.5	5.5	5.5	5.7	5.7	5.7	5.7
	4.4	Lift	h ₃ (in)	118.1	118.1	118.1	118.1	118.1	118.1	118.1	118.1	118.1	118.1
	4.5	Height, mast extended	h ₄ (in)	155.7	155.7	159.3	159.3	159.3	159.3	163.2	163.2	163.2	163.2
	4.7	Height of Overhead Guard (cabin)	h ₆ (in)	83.7(86.8*)	83.7(86.8*)	84.1(87.2*)	84.1(87.2*)	84.1(87.2*)	84.1 (87.2*)	84.6(87.8*)	84.6 (87.8*)	84.6(87.8*)	84.6 (87.8*)
	4.15	Fork Carriage Width	in	39.3	39.3	40.9	40.9	40.9	40.9	43.3	43.3	43.3	43.3
	4.20	Length to Face of Forks	l ₂ (in)	90	90.9	99.6	99.6	102.6	102.6	107.5	107.5	110.2	110.2
	4.21	Overall Width	b ₁ (in)	42.5	42.5	45.5	45.5	45.5	45.5	48.2	48.2	48.2	48.2
	4.22	Fork Dimensions ISO 2331	s/e/l (in)	1.4×3.9×36.2	1.4×3.9×36.2	1.6×4.8×42	1.6×4.8×42	1.6×4.8×42	1.6×4.8×42	1.8×4.8×42	1.8×4.8×42	2.0×4.8×42	2.0×4.8×42
	4.31	Ground Clearance, laden, below mast	m ₁ (in)	4.5	4.5	4.5	4.5	4.5	4.5	5.1	5.1	5.1	5.1
	4.32	Ground Clearance, centre of wheelbase	m ₂ (in)	5.5	5.5	5.9	5.9	5.9	5.9	6.5	6.5	6.5	6.5
	4.35	Turning Radius	W _a (in)	78.3	79.3	85.8	85.8	88.4	88.4	92.7	92.7	95.1	95.1
		Minimum Right Angle Stacking Aisle Width (Add load length and clearance)	in	94.3	95.3	104.1	104.1	106.7	106.7	111.6	111.6	114.2	114.2
	Performance Data	5.1	Travel Speed, laden/unladen	mph	(-/12.4)	(-/12.4)	(-/11.8)	(-/11.5)	(-/11.8)	(-/11.5)	(-/11.1)	(-/11.5)	(-/11.1)
5.2		Lift Speed, laden/unladen	ft/min	104.4/-	104.4/-	110.2/-	118/-	110.2/-	118/-	88.6/-	98/-	75.8/-	87/-
5.3		Lowering Speed, laden/unladen	ft/min	98.4/-	98.4/-	98.4/-	98/-	98.4/-	98/-	98.4/-	98/-	98.4/-	98/-
5.5		Drawbar Pull, laden/unladen	lbf	4271	4271	(4720/-)	4388/-	(4720/-)	4388/-	(4946/-)	4613/-	(4946/-)	4613/-
5.7		Gradeability, laden/unladen*	%	(37/-)	(37/-)	(33/-)	(25/-)	(28/-)	(23/-)	(25/-)	(20/-)	(22/-)	(20/-)
Combustion Engine	7.1	Engine Manufacturer/Type		GCT/GK21LPG CERT	GCT/GK21LPG CERT	GCT/GK25LPG CERT	KUBOTA V2607-CR-E5B	GCT/GK25LPG CERT	KUBOTA V2607-CR-E5B	GCT/GK25LPG CERT	KUBOTA V2607-CR-E5B	GCT/GK25LPG CERT	KUBOTA V2607-CR-E5B
		Emission STD		EPA Certified	EPA Certified	EPA Certified	EPA/CARB Tier4 F	EPA Certified	EPA/CARB Tier4 F	EPA Certified	EPA/CARB Tier4 F	EPA Certified	EPA/CARB Tier4 F
	7.2	Engine Power	HP	54	54	61	50.2	61	50.2	61	50.2	61	50.2
	7.3	Rated Speed	r/min ³	2700	2700	2700	2400	2700	2400	2700	2400	2700	2400
	7.4	Number of Cylinders / Displacement	(-) / (in)	4/126	4/126	4/151.8	4/160	4/151.8	4/160	4/151.8	4/160	4/151.8	4/160
	7.10	Battery Voltage/Nominal Capacity	V/Ah	12/60	12/60	12/60	12/90	12/60	12/90	12/60	12/90	12/60	12/90
		Rated Torque	N·m/r/min	150/2000	150/2000	187/1600	171.5/1500	187/1600	171.5/1500	187/1600	171.5/1500	187/1600	171.5/1500
		Bore × Stroke	in	3.5×3.3	3.5×3.3	3.5×3.9	3.4×4.3	3.5×3.9	3.4×4.3	3.5×3.9	3.4×4.3	3.5×3.9	3.4×4.3
		Transmissions Manufacturer		HANGCHA	HANGCHA	HANGCHA	HANGCHA	HANGCHA	HANGCHA	HANGCHA	HANGCHA	HANGCHA	HANGCHA
		Transmissions Type		Powershift	Powershift	Powershift	Powershift	Powershift	Powershift	Powershift	Powershift	Powershift	Powershift
	Stage FWD/RVS		1/1	1/1	1/1	1/1	1/1	1/1	1/1	1/1	1/1	1/1	
Additional Data	10.1	Operating Pressure for Attachments	bar	145	145	175	175	175	175	175	175	175	
	10.4	Fuel Tank Capacity	gal	7.4	7.4	10.6	10.6	10.6	10.6	10.6	10.6	10.6	

Note: *With suspension seat or cabin
*As a calculated value

XF Series Pneumatic Forklift 4,000-7,000lb Dual Fuel Specification

		HANGCHA GROUP CO.,LTD.				
Distinguishing Marks	1.1 Manufacturer					
	HCFA Model		FPG20B	FPG25B	FPG30B	FPG35B
	1.2 Manufacturer's Type Designation		CPQYD20-XW72B	CPQYD25-XW72B	CPQYD30-XW72B	CPQYD35-XW72B
	1.3 Drive: electric (battery or mains), diesel, petrol, fuel gas		(LPG)/(GASOLINE)	(LPG)/(GASOLINE)	(LPG)/(GASOLINE)	(LPG)/(GASOLINE)
	1.5 Rated Capacity/Rated Load	Q (lb)	4000	5000	6000	7000
	1.6 Load Centre Distance	c (in)	24	24	24	24
	1.8 Load Distance, centre of drive axle to fork	x (in)	18.3	18.3	18.9	19.1
	Rear Overhang	in	16.3	19.3	21.7	24.2
	1.9 Wheelbase	y (in)	65.0	65.0	66.9	66.9
Weight	2.1 Service Weight	lb	7491	8283	9570	10351
	2.2 Axle Loading, laden front/rear	lb	10351/1540	12045/1738	14190/1980	15961/2090
	2.3 Axle Loading, unladen front/rear	lb	3542/3949	3432/4851	3850/5720	3784/6567
Tires & Chassis	3.2 Tire Size, front		7.00-12-12PR	7.00-12-12PR	28×9-15-14PR	28×9-15-14PR
	3.3 Tire Size, rear		6.00-9-10PR	6.00-9-10PR	6.50-10-10PR	6.50-10-10PR
	3.6 Tread, front	b10 (in)	38.0	38.0	39.6	39.6
3.7 Tread, rear	b11 (in)	38.3	38.3	38.4	38.4	
Dimensions	4.1 Tilt of Mast/Fork Carriage Forward/Backward	$\alpha/\beta(^{\circ})$	6/12	6/12	6/12	6/12
	4.2 Height, mast lowered	h1 (in)	80.1	80.1	80.7	85.2
	4.3 Free Lift	h2 (in)	5.5	5.5	5.7	5.7
	4.4 Lift	h3 (in)	118.1	118.1	118.1	118.1
	4.5 Height, mast extended	h4 (in)	159.3	159.3	163.2	163.2
	4.7 Height of Overhead Guard (cabin)	h6 (in)	84.1(87.2*)	84.1 (87.2*)	84.6 (87.8*)	84.6 (87.8*)
	4.15 Fork Carriage Width	in	40.9	40.9	43.3	43.3
	4.20 Length to Face of Forks	l2 (in)	99.6	102.6	107.5	110.2
	4.21 Overall Width	b1(in)	45.5	45.5	48.2	48.2
	4.22 Fork Dimensions ISO 2331	s/e/l (in)	1.6×4.8×42	1.6×4.8×42	1.8×4.8×42	2.0×4.8×42
	4.31 Ground Clearance, laden, below mast	m1 (in)	4.5	4.5	5.1	5.1
	4.32 Ground Clearance, centre of wheelbase	m2 (in)	5.9	5.9	6.5	6.5
	4.35 Turning Radius	Wa (in)	85.8	88.4	92.7	95.1
	Minimum Right Angle Stacking Aisle Width (Add load length and clearance)	in	104.1	106.7	111.6	114.2
	Performance Data	5.1 Travel Speed, laden/unladen	mph	(-/11.8)	(-/11.8)	(-/11.1)
5.2 Lift Speed, laden/unladen		ft/min	110.2/-	110.2/-	88.6/-	75.8/-
5.3 Lowering Speed, laden/unladen		ft/min	98.4/-	98.4/-	98.4/-	98.4/-
5.5 Drawbar Pull, laden/unladen		lbf	(4720/-)	(4720/-)	(4946/-)	(4946/-)
5.7 Gradeability, laden/unladen*		%	(33/-)	(28/-)	(25/-)	(22/-)
Combustion Engine	7.1 Engine Manufacturer/Type		GCT/GK25 DUAL	GCT/GK25 DUAL	GCT/GK25 DUAL	GCT/GK25 DUAL
	Emission STD		EPA Certified	EPA Certified	EPA Certified	EPA Certified
	7.2 Engine Power	HP	(61.9)/(60.5)	(61.9)/(60.5)	(61.9)/(60.5)	(61.9)/(60.5)
	7.3 Rated Speed	r/min ³	2700	2700	2700	2700
	7.4 Number of Cylinders/Displacement	(-)/ (in)	4/151.8	4/151.8	4/151.8	4/151.8
	7.10 Battery Voltage/Nominal Capacity	V/Ah	12/60	12/60	12/60	12/60
	Rated Torque	N·m/r/min	(186/1600)/(175/1600)	(186/1600)/(175/1600)	(186/1600)/(175/1600)	(186/1600)/(175/1600)
	Bore × Stroke	in	3.5×3.9	3.5×3.9	3.5×3.9	3.5×3.9
	Transmission Manufacturer		OKAMURA	OKAMURA	OKAMURA	OKAMURA
	Transmission Type		Powershift	Powershift	Powershift	Powershift
Stage FWD/RVS		1/1	1/1	1/1	1/1	
Additional Data	10.1 Operating Pressure for Attachments	bar	175	175	175	175
	10.4 Fuel Tank Capacity	gal	10.6	10.6	10.6	10.6

Note: *With suspension seat or cabin
*As a calculated value

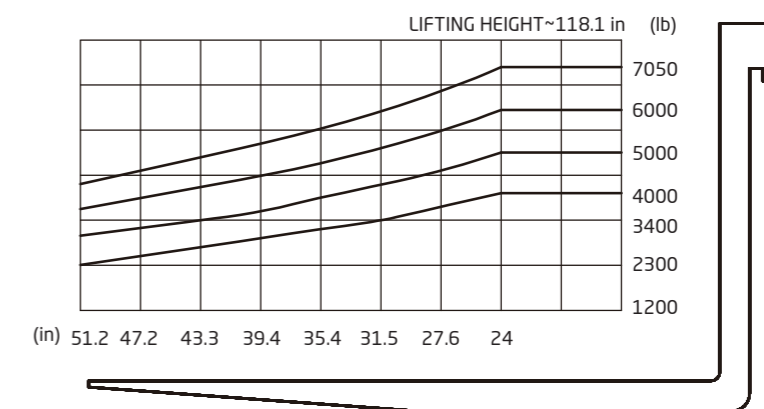
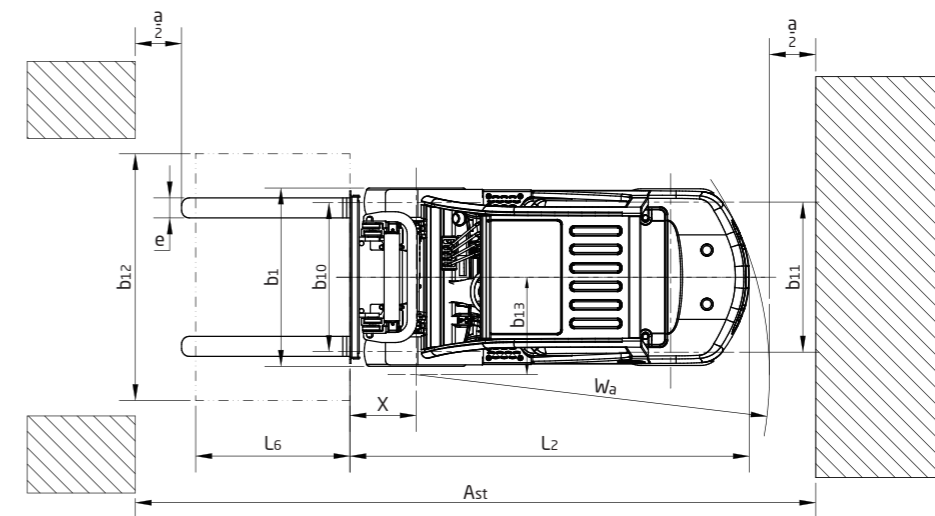
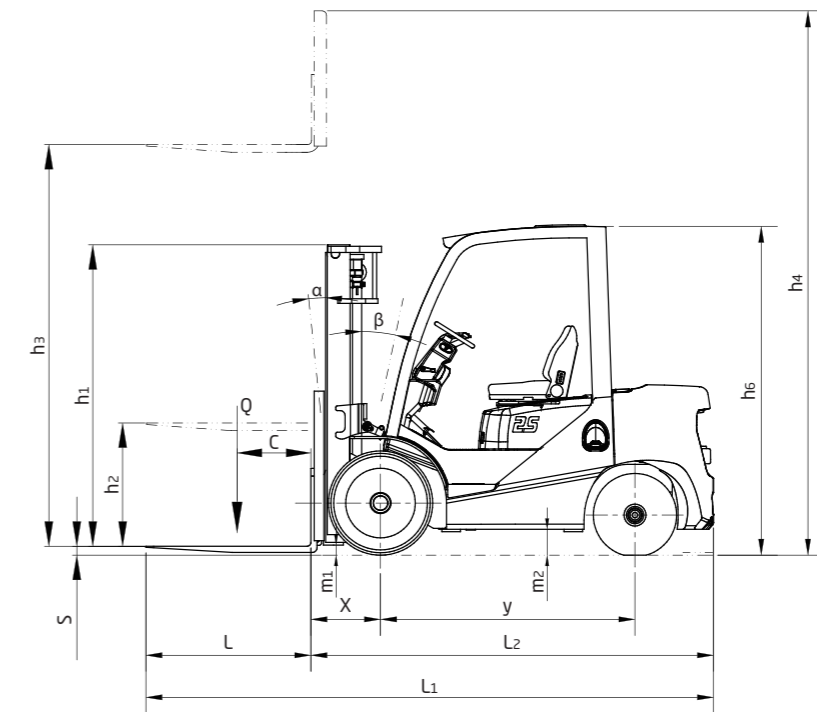

3,000-3,500 lb XF Series Mast:

Type	Model	Max. Fork Height	Overall Height				Free Lift		Front Overhang		Tilt Range		Capacity			
			Lowered	Extended		Without Backrest	With Backrest	3000lb	3500lb	FWD	BWD	Load Capacity at 24in				
				Without Backrest	With Backrest							Single Tire		Dual Tire		
			in	in	in	in	in	in	in	in	(°)	(°)	3000lb	3500lb	3000lb	3500lb
Limited Free Lift 2 Stage Mast	X15M330	129.9	84.4	152.2	167.5	6.1	6.1	15.9	16.1	6	12	3000	3500	3000	3500	
	X15M350	137.8	88.4	160.0	175.4	6.1	6.1	15.9	16.1	6	12	3000	3500	3000	3500	
	X15U300	118.1	79.1	141.3	155.5	56.1	41.9	15.9	16.1	6	12	3000	3500	3000	3500	
Full Free Lift 2 Stage Mast	X15U330	129.9	85.0	153.0	167.1	62.0	47.8	15.9	16.1	6	12	3000	3500	3000	3500	
	X15U350	137.8	89.0	160.8	175.0	65.9	51.8	15.9	16.1	6	12	3000	3500	3000	3500	
Full Free Lift 3 Stage Mast	X15N430	169.3	81.5	196.1	206.9	55.1	44.3	16.5	16.7	6	6	2700	3000	2700	3100	
	X15N450	177.2	83.5	202.0	214.8	59.1	46.3	16.5	16.7	6	6	2600	2900	2600	3000	
	X15N470	185.0	85.4	211.8	226.4	62.4	48.2	16.5	16.7	6	6	2500	2800	2500	2900	
	X15N500	196.9	89.4	220.3	234.4	66.3	52.2	16.5	16.7	6	6	2400	2700	2500	2900	
	X15N550	216.5	97.2	240.0	254.1	74.2	60.0	16.5	16.7	3	6	1900	2100	2300	2600	

With sideshifter, subtract 300lbs. With integral sideshifter, subtract 200lbs.

4,000-5,000lb XF Series Mast:

Type	Model	Max. Fork Height	Overall Height				Free Lift		Front Overhang		Tilt Range		Capacity			
			Lowered	Extended		Without Backrest	With Backrest	4000lb	5000lb	FWD	BWD	Load Capacity at 24in				
				Without Backrest	With Backrest							Single Tire		Dual Tire		
			in	in	in	in	in	in	in	in	(°)	(°)	4000lb	5000lb	4000lb	5000lb
Limited Free Lift 2 Stage Mast	X25M330	129.9	86.0	155.9	171.1	5.5	5.5	18.3	6	12	4000	5000	4000	5000		
	X25M350	137.8	90.0	163.8	178.9	5.5	5.5	18.3	6	12	4000	5000	4000	5000		
Full Free Lift 2 Stage Mast	X25U300	118.1	79.1	144.9	159.3	52.4	37.8	18.3	6	12	4000	5000	4000	5000		
	X25U330	129.9	85.0	156.7	171.1	58.3	43.7	18.3	6	12	4000	5000	4000	5000		
	X25U350	137.8	89.0	164.6	178.9	62.2	47.6	18.3	6	12	4000	5000	4000	5000		
Full Free Lift 3 Stage Mast	X25N430	169.3	82.7	196.9	210.4	55.1	41.5	18.9	6	6	3800	4800	3900	4900		
	X25N450	177.2	84.6	205.9	220.3	57.9	43.5	18.9	6	6	3700	4600	3700	4600		
	X25N470	185.0	86.6	211.8	226.2	59.8	45.5	18.9	6	6	3600	4500	3600	4600		
	X25N500	196.9	90.6	223.6	238.0	63.8	49.4	18.9	6	6	3400	3800	3600	4200		
	X25N550	216.5	98.4	243.3	257.7	71.7	57.3	18.9	3	6	2900	3200	3200	3800		

With sideshifter, subtract 330lbs. With integral sideshifter, subtract 220lbs.

6,000-7,000lb XF Series Mast:

Type	Model	Max. Fork Height	Overall Height						Free Lift				Front Overhang		Tilt Range		Capacity			
			Lowered (in)	Extended		Without Backrest	With Backrest	Without Backrest	With Backrest	6000lb	7000lb	6000lb	7000lb	FWD	BWD	Load Capacity at 24in				
				Without Backrest	With Backrest											Single Tire		Dual Tire		
			in	6000lb	7000lb	6000lb	7000lb	6000lb	7000lb	6000lb	7000lb	6000lb	7000lb	(°)	(°)	6000lb	7000lb	6000lb	7000lb	
Limited Free Lift 2 Stage Mast	X30/35M330	129.9	86.6	91.1	158.9	162.0	175.0	175.0	5.7	5.7	5.7	5.7	18.9	19.1	6	12	6000	7000	6000	7000
	X30/35M350	137.8	90.6	95.1	166.7	169.9	182.9	182.9	5.7	5.7	5.7	5.7	18.9	19.1	6	12	6000	7000	6000	7000
Full Free Lift 2 Stage Mast	X30/35U300	118.1	81.9	85.8	147.8	150.8	163.2	163.2	52.2	53.1	36.8	40.7	18.9	18.9	6	12	6000	7000	6000	7000
	X30/35U330	129.9	87.8	91.7	159.6	162.6	175.0	175.0	58.1	59.1	42.7	50.6	18.9	18.9	6	12	6000	7000	6000	7000
	X30/35U350	137.8	91.7	95.7	167.5	170.5	182.9	182.9	62.0	63.0	46.7	54.5	18.9	18.9	6	12	6000	7000	6000	7000
Full Free Lift 3 Stage Mast	X30/3N430	169.3	83.3	87.2	199.0	202.0	214.4	214.4	53.5	54.5	38.2	42.1	19.5	19.5	6	6	6000	7000	6000	7000
	X30/3N450	177.2	85.2	89.2	208.9	211.8	224.2	224.2	55.5	56.5	40.2	44.1	19.5	19.5	6	6	6000	6800	6000	7000
	X30/3N470	185.0	87.2	91.1	214.8	217.7	232.1	232.1	57.5	58.5	42.1	46.1	19.5	19.5	6	6	5600	6600	5800	6700
	X30/3N500	196.9	91.1	95.1	226.6	229.5	241.9	241.9	61.4	62.4	46.1	50.0	19.5	19.5	6	6	5200	5900	5300	5800
	X30/3N550	216.5	99.0	101.0	246.3	249.2	261.6	261.6	69.3	68.3	53.9	55.9	19.5	19.5	3	6	4500	4600	4800	5300

With sideshifter, subtract 440lbs. With integral sideshifter, subtract 220lbs.

XF Series Four Cylinder Mast (3 Stage Full Free Lift Mast)

	Model	Max. Fork Height	Lowered Height	Extended with Backrest	Extended without Backrest	Free Lift with Backrest	Free Lift Without Backrest
		inch	inch	inch	inch	inch	inch
4000-5000lbs	X25D400-000000-000	157	80	199	185	39	53
	X25D450-000000-000	177	86	219	204	45	59
	X25D470-000000-000	185	89	227	212	48	62
	X25D500-000000-000	197	93	238	224	52	66
	X25D550-000000-000	217	101	258	245	60	75
6000lbs	X30D400-000000-000	157	80	203	187	35	51
	X30D450-000000-000	177	87	223	207	42	57
	X30D470-000000-000	185	89	230	215	44	60
	X30D500-000000-000	197	93	242	227	49	64
	X30D550-000000-000	217	102	262	247	57	72
7000lbs	X35D400-000000-000	157	82	203	190	37	50
	X35D450-000000-000	177	89	223	210	44	57
	X35D470-000000-000	185	92	230	218	47	59
	X35D500-000000-000	197	96	242	230	51	63
	X35D550-000000-000	217	102	262	250	57	70

Easy
Efficient
Economical

